

Introduction

Across every major industry and in every major marketplace worldwide, sustainability is gaining heightened priority in the 21st century business world. And the reasons behind the push for “greener” operations are both powerful and promising, as some of the same practices that can help preserve the planet can also help businesses save money and boost their bottom lines.

The primary avenue for industries to achieve this goal — sustainability-based production — focuses on reducing electricity consumption to both cut CO₂ emissions and generate substantial savings for the enterprises that implement it. And optimized compressed air can be a big step toward making it happen.

Optimizing your compressed air is not just about today — it’s about tomorrow, too. Kids love to make footprints and leave a lasting impression, but have you ever thought about the footprint and lasting impression that your production leaves?

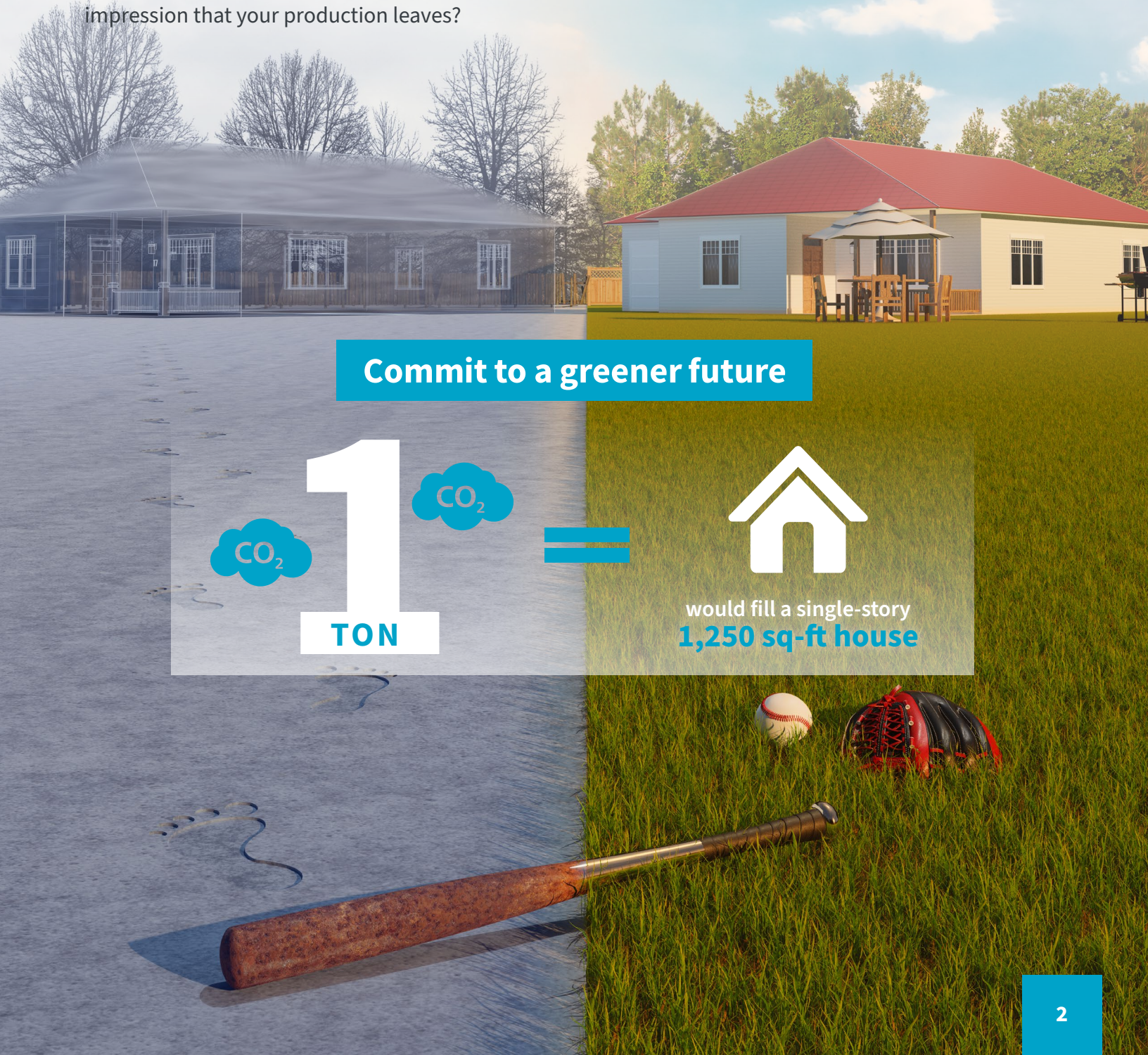

Commit to a greener future



The Compressed Air Opportunity

Reducing electricity consumption and cutting costs are key to keeping U.S. manufacturing competitive. And — described by many as the “fourth utility” inside a plant after gas, electricity and water — compressed air systems present huge opportunities for industry leaders to do both by optimizing their efficiency.

Improving compressed air efficiency is certainly on the minds of industry leaders and decision-makers. In fact, in a 2021 survey published by of more than 50,000 engineers, contractors and plant personnel throughout the U.S. regarding their compressed air, benchmarking compressed air systems for efficiency tied for second place among respondents’ leading concerns, with 16% ranking this as their top consideration. Further, among the top questions Atlas Copco is asked the most: How much more efficient are air compressors today, compared to 5-10 years ago?

The answer (depending on type) is “substantially” — and as such, upgrading compressed air systems presents big opportunities.

With this in mind, Atlas Copco Compressors decided to take a more in-depth look at the U.S. market when it comes to compressed air. The analysis of the market concluded that United States manufacturing has a compressed air installed base of at least 15 million horsepower. Based on looking at various air audits across different customer types, sizes and segments, the analysis concluded that the U.S. could save around 13 billion kWh annually in electricity associated with compressed air — which would save U.S. manufacturers over \$1 billion in energy costs annually. As importantly, this would remove ~9 million metric tons of CO₂ annually — equivalent to >1 million homes’ annual electricity usage.

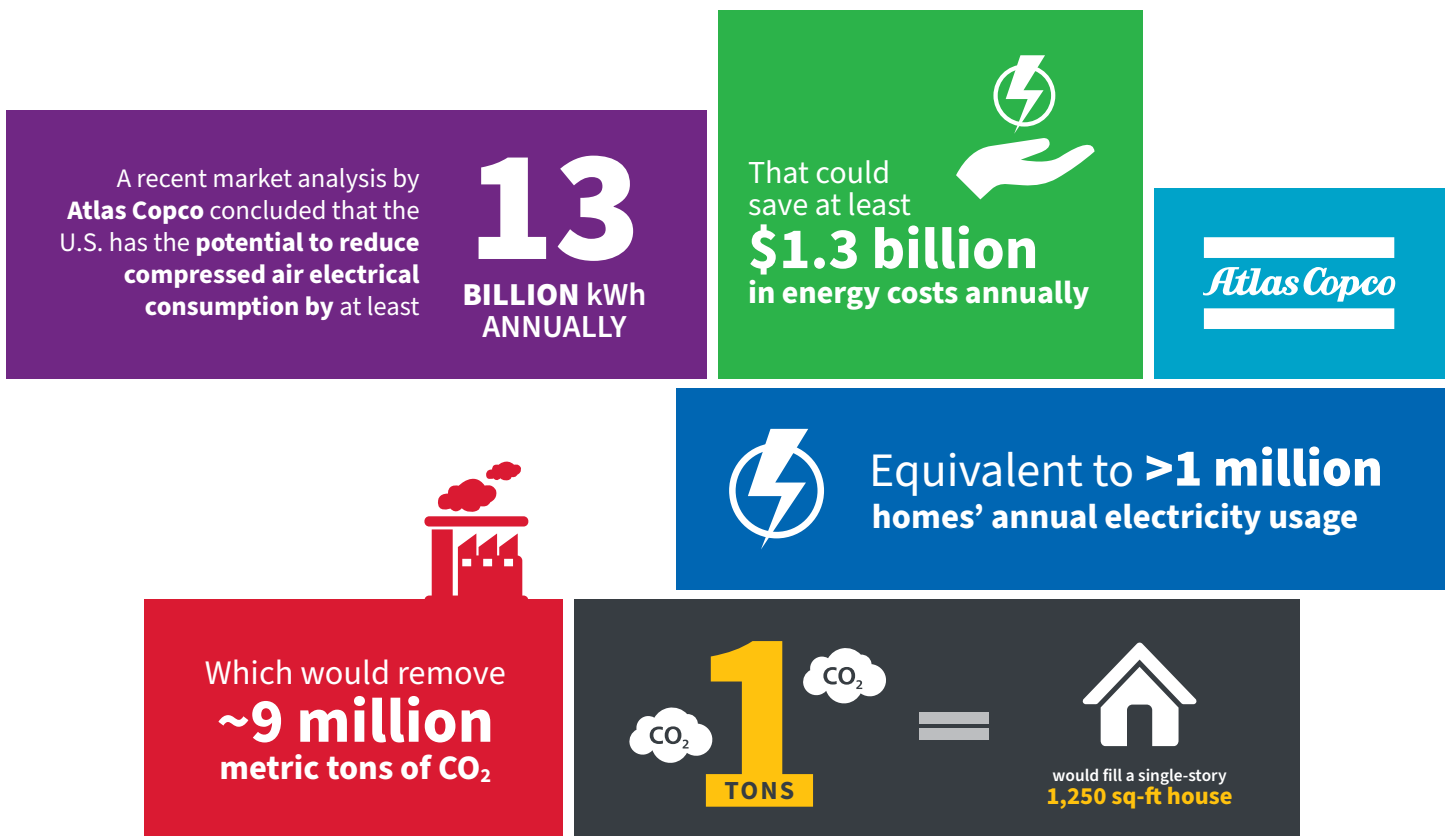

The image above shows the results of Atlas Copco’s market study in 2022.

The Government's Role

Held in late 2021, the [26th United Nations Climate Change Conference \(COP26\)](#) saw more than 120 world leaders come together in Glasgow, Scotland, in an effort to enact climate change-countering policies globally. Some of the most potentially impactful results of the gathering included a pact urging countries to phase down fossil fuel and coal subsidies, plus pledges by 130-plus countries possessing 90% of the world's forests to halt and reverse deforestation — all in addition to pledges to cut methane emissions, make moves toward zero-emission vehicles and more.

Here in the United States, to help ensure nationwide energy efficiency in the compressed air industry, the U.S. Department of Energy has established soon-to-be-enforced [minimum efficiency standards](#) for compressors. Set to become mandatory in January 2025, the new regulations were established with input from all major compressor manufacturers. And, during

the three decades starting with the first full year of their enforcement, the updated regulations are estimated to deliver a lifetime energy savings of over 15 billion kilowatt-hours — which equates to the amount of energy needed to power 1.6 million homes for a year.

California, of course, has long led the charge in the U.S. regarding environmental sustainability regulations — and the regulation of air compressor energy efficiency is no exception. To that point, in 2019, California's state energy commission set its own [new requirements for commercial and industrial air compressors](#), with the new rules becoming effective in January 2022. The new regulations effectively mimic the previously referenced federal regulations set to be enforced starting in 2025, more quickly setting stricter standards for any large, lubricated, rotary air compressors sold in California.



Reducing electricity costs is one of the keys to keeping U.S. manufacturing competitive.



The associated CO₂ savings that accompany this would make a major difference in the fight against climate change.



It's almost impossible for a company to make its sustainability goals without having an efficient compressed air and gas system.



A Pressing Problem — And a Promising Solution

Published in August 2021, [the latest climate change report from the Intergovernmental Panel on Climate Change \(IPCC\)](#) — prepared by 234 scientists from 66 countries — conveyed a “code red for humanity.” But the report also stressed that it’s not too late to limit climate change. And sustainability-based production offers a new definition of the top-line priorities businesses can employ to reduce both their CO₂ emissions and their costs.

Reducing your carbon footprint through the use of efficient compressed air is among the biggest gifts you can give to the world. And the best part? It’s very much about creating savings today, as well! Big efficiency savings will help you meet your sustainability goals and push more dollars straight to your bottom line. And the business case to upgrade to more efficient air compressor technology can be clearly shown before the investment is made.

What Are Your Sustainability Goals?

Is your company looking to increase its environmental sustainability? Leading companies worldwide are making major moves to do their part in contributing to a greener tomorrow for the planet and its inhabitants.

To inspire your own sustainability-focused goals, consider these efforts being made by some of the planet’s most recognized corporations:

- **Apple** — which already uses solely renewable wind and solar energy at its production facilities — has committed to working with [Conservation International](#) to replant 27,000 mangrove trees along Colombia’s coastline.
- **Dell** has committed to cutting its carbon emissions in half by 2030, in addition to beefing up its recycling programs and using more renewable energy.
- **Microsoft, Facebook** and **Google** have made a commitment to be “water positive” by 2030, meaning that they will replenish more water than they use in their operations. **BP** has pledged to do the same by 2035, and **Gap’s** target year for this achievement is 2050.
- With a 2018 initiative, **Target** employed recycling programs to cut the amount of waste it sends to landfills by 75%. The retailer has also pledged to go 100% solar with its energy consumption by 2030, and in support of this goal, it completed the addition of solar panels to its 500th store rooftop in 2020.

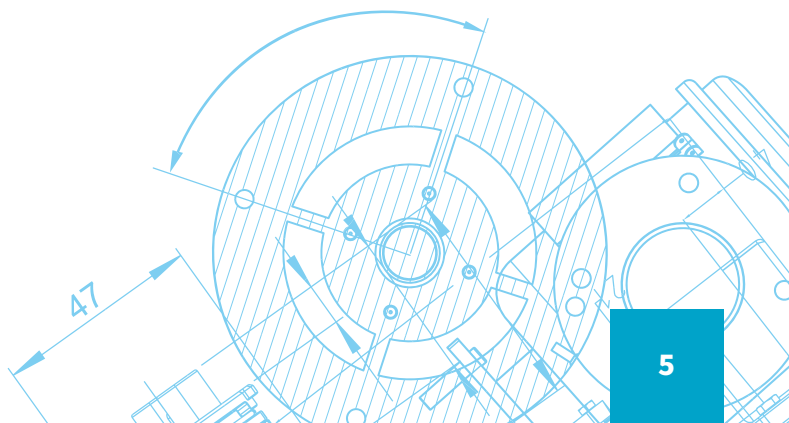

Atlas Copco's Sustainability-Supporting Efforts

Striving to be an industry leader in sustainability — and to create a better tomorrow by maximizing efficiency today — Atlas Copco is driven to stay well ahead of the curve when it comes to reducing its environmental impact. Demonstrating this, two of the six focus areas included in its corporate mission — Products & Service and The Environment — outline the commitment to eco-friendly initiatives held by a world leading producer of air compressors:

Focus Area	Goal	Target
Products & Service 	Projects for new or redesigned products have clear and specific targets set for reduced carbon impact.	100% by end of 2021
	Projects for new and redesigned products achieve significant carbon reduction.	Divisional targets
The Environment 	Reduced CO ₂ emissions from energy in operations and transport (tons) in relation to cost of sales. Base year: 2018.	50% by 2030
	Reduced waste (kg) in relation to cost of sales.	Continuous reduction
	Reduced water consumption (m ³) in relation to cost of sales.	Continuous reduction



THE GOALS AND FOCUS OF THE ATLAS COPCO GROUP IS FULLY ALIGNED WITH THOSE OF OUR CUSTOMERS.

- We prioritize safety first.
- We have goals to reduce our CO₂ emissions. We lead the way in our industry, having signed up to science-based targets to reduce global temperate rises.
- Remote monitoring and direct access put you in control with an ongoing focus to reduce waste.
- Diversity and Inclusion are critical to our long-term success and being customer-centric. We build teams with this focus in mind.
- Every Atlas Copco employee is trained annually in the Business Code of Practice, which sets out the way we act and behave.

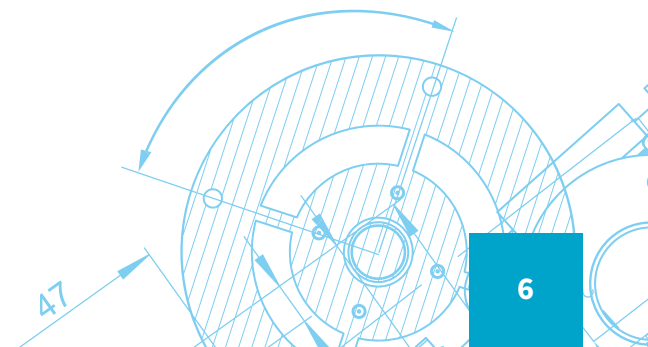

In 2021, Atlas Copco committed itself to, in line with the goals of the Paris Agreement, employ science-based targets to reduce its greenhouse gas emissions. (To learn more about Atlas Copco’s commitment to achieving these science-based targets and reducing its carbon footprint, check out [this interview](#) with Sofia Svingby, Vice President of Sustainability for the Atlas Copco Group.)

The adoption of these science-based targets will step up Atlas Copco’s efforts to, beyond supplying the most energy-efficient products and solutions possible to customers, incorporate earth-friendly practices across its range of operations. Among the areas of focus:

- Buying renewable electricity
- Installing solar panels
- Switching to bio-fuels in portable compressor testing
- Implementing energy conservation measures
- Logistics planning improvements, as well as switching to more environmentally friendly transport
- Supporting customers aiming to reach their own sustainability ambitions

With the commitment, Atlas Copco is aiming to reduce the emissions from its direct operations by 46% by 2030, compared to its 2019 baseline. It also aims to reduce its value chain emissions — primarily targeting the carbon impact of its products in use — by 28% by 2030 compared to its 2019 level of emissions.

Further, Atlas Copco’s commitment to making the world a better place for current and future generations extends beyond environmental initiatives. As a company, Atlas Copco wholeheartedly endorses the [United Nations’ 17 Sustainable Development Goals](#), which are designed to serve as a road map to global peace and prosperity — both today and moving into the future. In particular, the company strives to directly contribute to seven of the 17 outlined goals in its operations, including:

- Gender equality
- Clean water and sanitation
- Affordable and clean energy
- Decent work and economic growth
- Industry, innovation and infrastructure
- Responsible consumption and production
- Peace, justice and strong institutions

A Real-World Example

One real-world example, that of [Utah packaging company COMPAX](#), clearly exhibits the financial and environmental advantages companies can leverage by increasing air compressor efficiencies in their operations.

By adding a smaller positive displacement compressor to its existing centrifugal compressor installation — a move that allowed the company to operate the smaller compressor when system demand was too low to operate its centrifugal compressors without risking damage to their mechanical integrity — COMPAX was able to harness a range of benefits.

Among them:

kWh Annual Savings:	933,791
Annual Electricity Cost Savings:	\$84,298.96
Annual Reduction in CO ₂ Emissions:	600 metric tons (equivalent to annual electricity usage of 112 average homes)
Project Cost:	\$312,243.49
Energy Incentive:	\$140,068.65
NET Project Cost:	\$172,174.84
Payback Period	2 years



Two More Key Considerations of Optimization:

1. Energy Recovery

You can further optimize an already efficient system by utilizing energy recovery modules, which can now also be supplied built into the products.

The potential for energy recovery lies in the fact that heat is formed when air is compressed. In most cases, the heat energy is extracted — and becomes waste heat — before the compressed air is distributed into a facility's pipe system. But substantial amounts of waste heat, even representing as much as 94% of the energy supplied to a compressor, can be recovered via hot air or hot water (depending on air cooled or water cooled).

This can quickly provide a substantial return on investment for companies that capture the heat energy. Further, when energy is recovered via a closed cooling system, it enhances compressor [operating conditions](#), reliability and service life thanks to — among other advantages — an equalized temperature level and high cooling water quality. And most major suppliers' medium to large compressors now offer adaptations for fitting with standard waste heat recovery equipment.

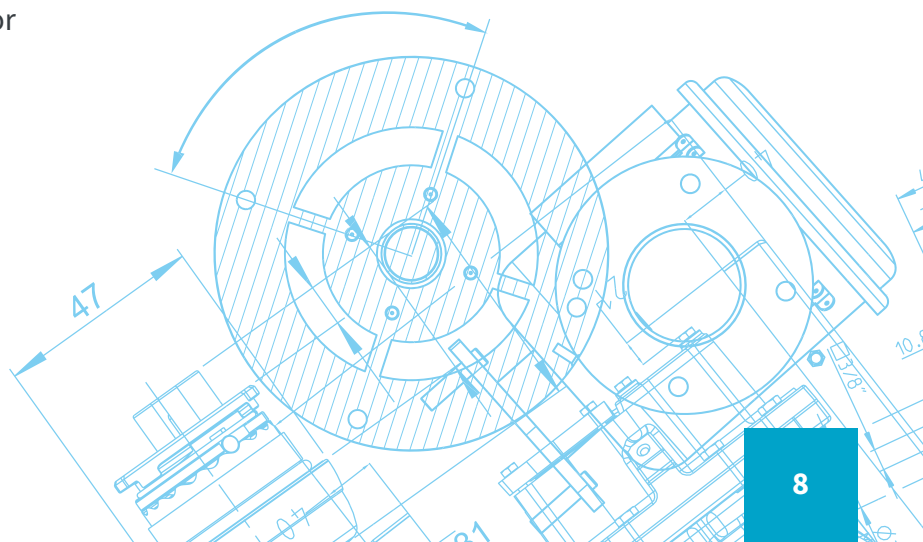



Two More Key Considerations of Optimization:

2. Water

In addition, in applications where a company can switch from a water-cooled air compressor to an air-cooled compressor, the cooling water used by a water-cooled compressor can, of course, be eliminated. A water-cooled, 200-horsepower air compressor could easily use over 7 million gallons of water annually, and with treatment and processes could cost close to \$50,000 per year. With air-cooled compressors, there is no need for using gallons of water — it's better for the environment and saves money.

There is also no need for:

- Cooling towers.
- Water pumping skids.
- Extra additional wiring for auxiliaries used for water.

- Maintenance of auxiliaries used for water.
- Scaling of coolers due to water contaminants.
- Cost to clean fouled coolers due to water.
- Additional water piping from cooling tower to compressor.

Of course, water-cooled compressors are essential for certain applications, and there are ways to optimize the process when this is the case.

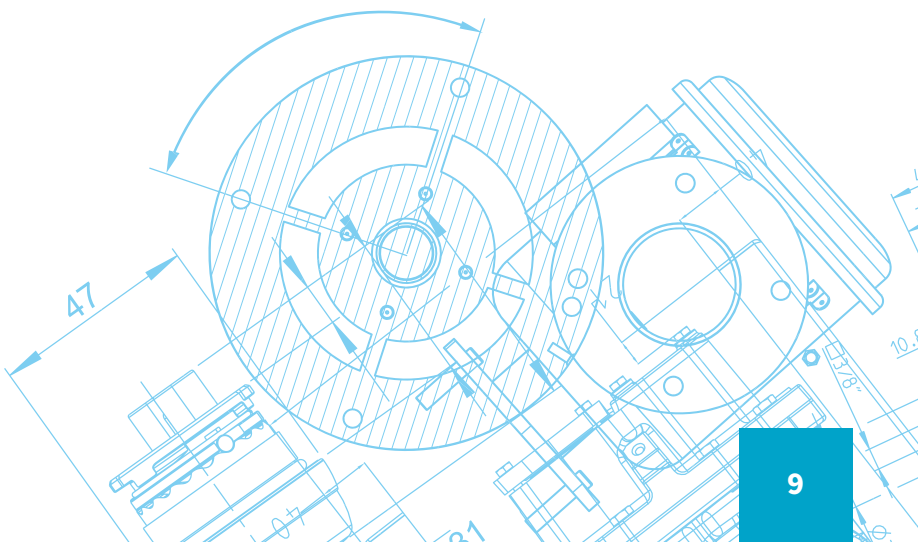

Is Your Compressed Air System Efficient?

Here are five things that might indicate it's time to consider optimizing the efficiency of your compressed air system:

- 1 You see the manufacturer's compressor service team more often than your dentist.**
- 2 You feel like you need to wipe your feet when leaving the compressor room.**
- 3 You need to shout if chatting with a colleague when standing near your compressor.**
- 4 You can't monitor your compressor system unless you're standing next to it (no remote access).**
- 5 You are not able to view simple energy-output graphs for the performance of your compressor.**

Simple Next Steps Toward Sustainability

Is your company looking to make its compressed air production more environmentally friendly and less expensive — both immediately and sustainably? For those looking to take the journey, there are a number of simple, no-cost steps to increasing your operation's compressed air sustainability.

When you're ready to save money and energy while reducing your carbon footprint, consider taking these next steps:

- Conduct an [air study](#) — there's one for everyone. (And here's an example of what a [free air study report from Atlas Copco](#) looks like.)
- [Check out Atlas Copco's 10-step guide to lowering your energy consumption and carbon footprint](#), the sum of which can generate (often substantial) financial savings.

“Our mission is to save U.S. manufacturers over \$1 billion in annual electricity costs, while reducing CO₂ emissions by 9 million metric tons.”



What size is your compressor?

Savings are possible (and potentially massive) across all sizes. Here's an example based on 50-horsepower. You can scale up or down to work out what might be possible within your facility.



An inefficient compressor can easily consume **~148,000 kWh**

50 HP
COMPRESSOR
Example

Optimization and ensuring the best technology can **reduce energy consumption by**

~30%



Reducing energy consumption by **~44,000 kWh**



Saving **9 metric tons of CO₂** and \$\$\$\$ on electricity!

Start the **connected efficiency journey today** with a free baseline air study



Audit



Design/Install



Optimize



Monitor



Service & Support

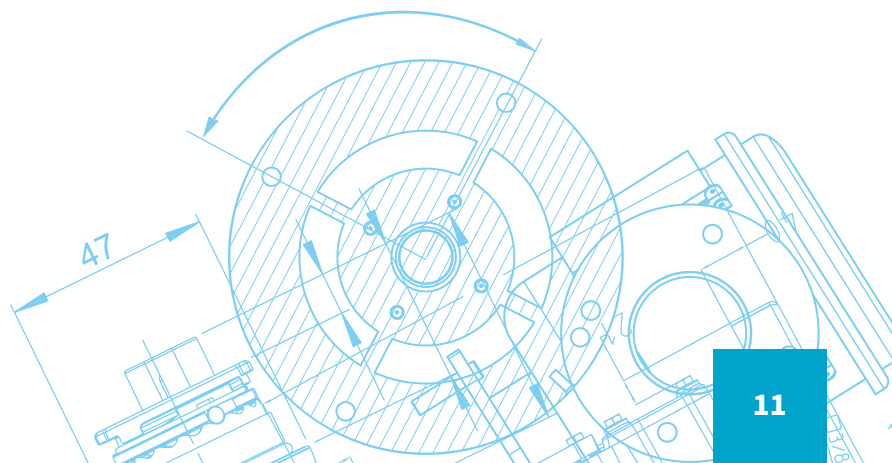

Atlas Copco

Atlas Copco Compressors

300 Technology Center Drive Ste 550
Rock Hill, South Carolina 29730
atlascope.com/air-usa

